



GANESH INSTITUTE OF ENGINEERING AND TECHNOLOGY (GIET),  
Jagannath Prasad, Andharua, BHUBANESWAR

# RENEWABLE ENERGY (Th- 04)

(As per the 2019-20 syllabus of the SCTE&VT,  
Bhubaneswar, Odisha)



Sixth Semester

Electrical Engg.

**Prepared By:** Er. MADHUSMITA SAHOO

## **Th-4(B) .RENEWABLE ENERGY SYSTEMS**

### **Books Recommended**

- 1. Renewable Energy Source & Emerging Technologies-DP Kotha0ri,  
K.C. Singal, Rakesh Ranjan.**
- 2. Non-Conventional Energy Resources-B.H. Khan.**
- 3. Non-Conventional Energy Resources &Utilisation-R.K Rajput**

<b>SI No.</b>	<b>Topic</b>	<b>Expected Mark</b>
1.	Introduction to Renewable Energy	20
2.	Solar Energy	20
3.	Wind Energy	20
4.	Biomass Power	20
5.	Other Energy Sources	20
Total		100

### **CHAPTER -1**

#### **INTRODUCTION TO RENEWABLE ENERGY**

##### **Renewable Energy**

- Renewable energy is often referred to as clean energy that comes from natural sources or processes that are constantly replenished. Example- Solar Energy, Wind Energy.
- Non-renewable or dirty energy are available in limited amounts and take long time to replenish. Example- fossil fuels such oil, gas, coal.

##### **1.1 Environmental Consequences Of Fossil Fuel Use**

- These are energy rich substances formed from long buried plants and micro-organisms. Example- coal, crude oil, natural gas.
- The use of fossil fuels have the following Environmental consequences

**Emission**-Fossil fuels are burned to release energy being rich in carbon concentration they release CO<sub>2</sub> and CO by incomplete combustion of carbon. Fine particle emissions known as particulate matter are also released

**Effects** :- Increase in CO<sub>2</sub> concentration in the atmosphere makes it warmer leading to global warming effect, these results in drastic climate condition such as floods, draughts etc.

Air pollutants such as NO<sub>x</sub> and SO<sub>x</sub> can travel long distances, chemically react in the atmosphere to produce acid rain and ozone.

## 1.2 Importance of Renewable Energy Source

- Large inexhaustible source.
- Available in nature free of cost.
- Clean source of energy.
- Availability varies with respect to time, geographic, location.
- They have low gestation period
- Can be developed into modular units.

## 1.3 Sustainable Design and Sustainable Development

- Global environmental degradation is one of the most serious threats faced by mankind.
- One of the international responses to global environmental problems is the Framework Convention on Climate Change was ratified and came into effect in March 1994.
- The convention aimed at reducing the emission of CO<sub>2</sub> and stabilizing it in developed countries.
- Attempts to restrict the use of fossil fuels for environmental reasons are likely to have a negative impact on economic development and the overall availability of energy.
- The three E's – environment, energy, and economic development are closely interrelated.
- Herman Daly a famous economist, laid down three conditions for sustainability.
  1. The consumption rate of renewable resources is not higher than its recovery rate.
  2. The consumption rate of non- renewable resources is not higher than the rate of increase in renewable resource supply.

3. The emission of pollutants is within the absorption capacity of the environment.
- A substantial reduction in resource consumption and emission of pollutants is essential for the development of a sustainable human society.

## **1.4 Types of Renewable Energy Source**

There are seven types of Renewable .

### 1 .Solar Energy

- Solar energy can be a major source of power and can be utilised by using thermal and photovoltaic conversion system.
- Its technologies are broadly characterised as either passive solar or active solar depending on how they capture or distribute solar energy or convert it into solar power.
- Active solar techniques include use of photovoltaic system, concentrated solar power and solar water heating to harness energy.
- Passive solar techniques include orienting a building to the sun, selecting materials with favourable thermal mass or light dispersing properties.
- The solar radiation received on earth surface on a bright sunny day at noon is approximately  $1\text{KW}/\text{m}^2$ .
- According to an estimate, if all buildings of the world are covered with solar PV panels, it can fulfill the electrical power requirements of the world.

### 2. Wind Energy

- Wind Energy is the use of wind to provide mechanical power through wind turbines to turn generators for electrical power.
- Wind energy is a popular sustainable, renewable source of power. Wind farms consist of many individual wind turbines ,which are connected to the electric power transmission network.
- The power available in the wind flowing over the earth surface is estimated to be  $1.6 \times 10^7 \text{MW}$ , which is more than the present energy requirement of the world.
- Wind power has emerged as the most economical of all renewable energy sources and it is the fastest growing energy sources.

- It accounts for approximately 19% of electricity production in Denmark, 9% in Spain and Portugal and 6% in Germany and the Republic of Ireland.

### 3. Biomass Energy

- Energy resources available from animal and vegetation are called biomass energy resources.
- The principal biomass are trees, cultivated plants grown for energy, urban waste, algae and other vegetation from oceans and lakes, rural waste.
- Biomass may be transformed by chemical or biological processes to produce bio fuels.
- Upgrading raw biomass to higher grade fuels can be achieved by different methods, broadly classified as thermal, chemical, or biochemical.

### 4. Geothermal Energy

- Geothermal energy is derived from huge amount of stored thermal energy in the interior of earth. Its overall contribution in total energy requirement is negligible.
- Global use of geothermal power is growing annually at a rate of 3% electrical and 7.5% thermal.
- Geothermal power is cost-effective, reliable, sustainable and environmental friendly.
- The oldest geothermal power generator is located at Lardarello in Italy.

### 5. Ocean Tidal Energy

- Tidal energy is a form of hydro power that converts energy of Ocean tides into electricity or other useful forms of power.
- Tides are more predictable than wind energy and solar power.
- Tidal power is taken from Oceanic tides. Tidal forces are periodic variations in gravitational attraction exerted by celestial bodies.
- The first and biggest tidal power plant was built in France having capacity of 240MW.

## 6. Ocean Wave Energy

- Wave power refers to the energy of ocean surface waves and the capture of that energy to do useful work.
- Good wave power locations have a flux of about 50 kilowatts per meter of shoreline.
- The world's first 2250MW commercial wave farm is based in Portugal.

## 7. Ocean Thermal Energy Conversion

- OTEC uses ocean thermal gradient between cooler deep and warmer shallow or surface seawaters to run a heat engine and produce useful work.
- The resource potential for OTEC is considered to be much larger than other ocean energy forms.
- OTEC systems are of two types closed -cycle, open-cycle
- OTEC technology is still in its infant stage. Conceptual design of small OTEC plants have been finalised.
- Their commercial prospective is very low.

### **1.5 LIMITATIONS OF RE SOURCE**

- Energy available is in dilute form from these sources.
- Cost of harnessing energy from these sources is high.
- Availability is uncertain.
- Difficulty in transporting such forms of energy.

### **1.6 PRESENT INDIA AND INTERNATIONAL SCENARIO OF CONVENTIONAL AND RE SOURCES**

The global energy supply and consumption is given in the table below

Table: Annual primary energy consumption by fuel (2012) in Mtoe\*

Country	Oil	Natural Gas	Coal	Nuclear Energy	Hydro-Electric	Renewable & Waste	Total
USA	884	594	615.7	83.8	28.2	77.3	2,283
Canada	152	83	31	9.4	68.6	NA	344
France	83	45	12.4	43.9	14.8	67.4	266.5
Russian Federation	494	438	153	16.3	35.6	NA	1136.9
United Kingdom	76.8	71.2	39.1	20.1	1.3	NA	208.5
China*	436	98.1	2500	12.3	58.5	103.1	3208
India*	205.5	47.1	352	4.1	11.4	98.4	718.5
Japan	199	93	71.6	25.8	8.3	98.1	495.8
Others	1807.3	1276.6	114.5	501.4	70.0	524.1	4293.9
Total	4337.6	2746	3889.3	717.1	296.7	968.4	12995.1

Mtoe → Million tons of oil equivalent.

---

## India's Energy Reserves:-

The Ministry of statistics and program Implementation, Govt. of India, 2012 has produced the following data.

Coal	Main fossil energy reserves in India at 286 billion tons and 41 billion tons of lignite. These are available in eastern and southern belts of the country.
Crude Oil	Limited to 757 million tons m <sup>3</sup> .
Natural Gas	Limited to 1241 billion tons m <sup>3</sup> .
Nuclear Energy	Uranium can fuel only 10,000 MW pressurized heavy water reactors (PHWR).

\*India depends primarily on *Uranium* to run the reactors. *Thorium* is also another source for nuclear energy which runs in *fast breeder reactor*. The *fast breeder reactor* has been rejected by Europe and USA due to safety concerns.

## Renewable Energy Sources:-

The capacity addition in renewable energy was about 27,300 MW in 2012.

Technology	Capacity Installed in MW by 2012.
Coal	11,202
Hydro	38,990
Renewable	27,300
Gas	18,381
Nuclear	4,780
Total	201,473

**Table: India's Installed power generation capacity.**

Thermal	54.4%
Hydro	21.60%
Renewable	10.90%
Gas	10.10%
nuclear	2.7%

11

So, total renewable energy's contribution becomes almost 33% (includes Hydro power), plan wise grid connected renewable energy contribution is given in Table below.

**Table: Power densities of *renewable energy sources* and the *conventional energy forms*.**

Renewable Energy Sources	in KW/m <sup>2</sup>
Wave	< 100
Extra terrestrial solar radiation	< 1.35
Wind	< 3
Solar radiation	0.2
Tidal	0.002
Biomass Production	0.002
Geothermal heat	0.00006

Conventional Energy	in KWh/m <sup>2</sup>
Hot Plate	100
Coal	500
Nuclear	650
Power Cable	1000,000

12

## QUESTION ANSWER

### Short question and answer

1. Define Renewable Energy and Non Renewable Energy

Ans -Renewable energy is often referred to as clean energy that comes from natural sources or processes that are constantly replenished. Example-Solar Energy, Wind Energy.

Non-renewable or dirty energy are available in limited amounts and take long time to replenish. Example- fossil fuels such oil, gas, coal.

2. Write the importance of renewable source of energy.

Ans-

- Large inexhaustible source.
- Clean source of energy.
- Availability varies with respect to time, geographic, location.
- They have low gestation period
- Can be developed into modular units.
- Available in nature free of cost

3. What are the types of RE source?

Ans-There are 7 types of RE Source.

1. Solar Energy
2. Wind Energy
3. Biomass Energy
4. Geothermal Energy
5. Ocean Tidal Energy
6. Ocean Wave Energy
7. Ocean Thermal Energy Conversion

4.What are the limitations of RE source?

Ans-The following are the limitations of RE sources.

- Energy available is in dilute form from these sources.
- Cost of harnessing energy from these sources is high.

- Availability is uncertain.
- Difficulty in transporting such forms of energy.

## **LONG QUESTIONS**

1. Write in brief about the types of RE source.
2. Briefly explain the energy scenario in India and world.

## **CHAPTER -2**

### **SOLAR ENERGY**

#### **2.1 SOLAR PHOTO VOLTAIC SYSTEM**

- Solar photovoltaic (PV) system convert solar energy directly into electrical energy.
- The basic conversion deice used is solar photo voltaic cell or solar cell.

#### **OPERATING PRINCIPLE**

- Semiconducting material in the PV cell are doped to form P-N structure as an internal electric field.
- The p-type(positive) silicon has a tendency to give up electrons and acquire holes, while n-type(negative) silicon accepts electrons. When sunlight hits the cell the electrons in the semiconductor gets excited to form electron-hole pair.
- Since there is an internal electric field, these pairs are induced to separate as a result the electrons move to negative electrodes while holes move to positive electrodes.
- A conducting wire connects the negative electrode, the load, and the positive electrode in series to form a circuit, as a result, an electric current is generated to supply the external load.

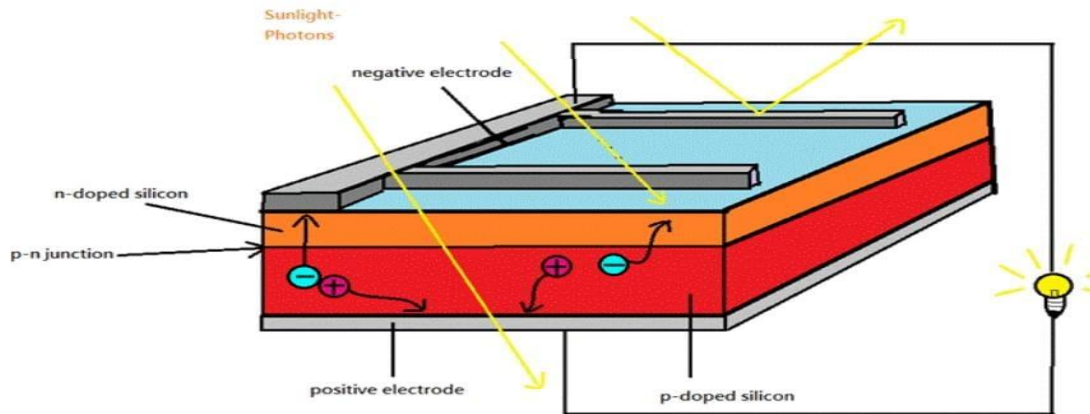

Fig 2.1

## 2.2 PHOTOVOLTAIC CELL

- Photovoltaic cell is a semiconductor device that converts light into electrical energy.
- The voltage induced by the PV cell depends upon the intensity of light incident on it.
- When the photons are incident on the electron they become energised and start emitting.
- The energised electrons are photoelectrons and the phenomenon of emission of electrons is photoelectric effect.

## SOLAR CELL, MODULE, ARRAY

### Solar Cell

- It is defined as an electrical device that converts light into electrical energy by photovoltaic effect.
- It is a form of photovoltaic cell whose electrical characteristics vary when exposed to light.

## Solar PV Module

- It is an assembly of photovoltaic cells to achieve required voltage and current.
- A solar panel is group of several modules connected in series- parallel combination in a frame that can be mounted on a structure.

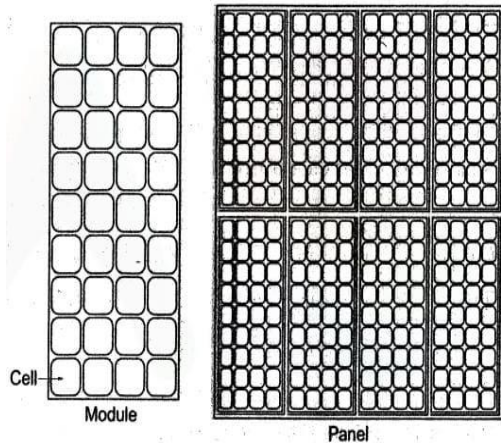

Fig 2.2

## Solar PV Array

- A large number of interconnected solar panels is known as solar PV array.

### 2.2.1 SERIES AND PARALLEL CONNECTIONS

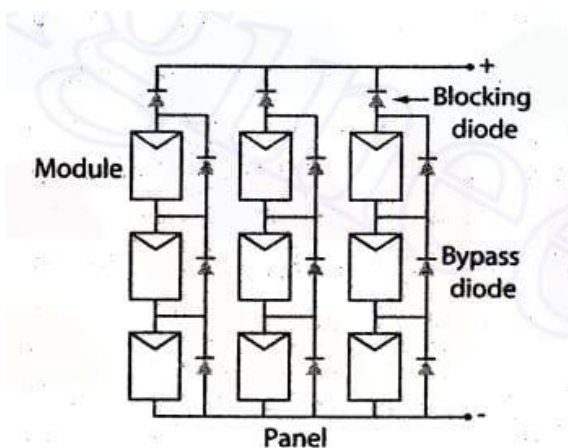

Fig-2.3

- The above figure shows the series -parallel connection of modules in a panel.
- In parallel connection blocking diodes are connected in series with each series string of modules. If any string fails the power output of remaining string is not absorbed by the failed string.
- Also bypass diodes are installed across each module, if one module fails, output of remaining modules in a string bypass the failed module.

### Maximum Power Point Tracker(MPPT)

- It is a device used in solar PV system to extract maximum power from solar pv module throughout all day.
- When a solar PV system is deployed for practical applications ,the I-V characteristics keeps on changing with isolation and temperature.
- In order to achieve maximum power the load must adjust itself accordingly to track the maximum power point
- Generally MPPT is an adaption of dc-dc switching voltage regulator, coupling to the load for maximum power transfer may require either providing a higher voltage at lower current or lower voltage at higher current.
- A buck-boost scheme along with voltage and current sensor are tied into a feedback loop using a controller to vary the switching time.

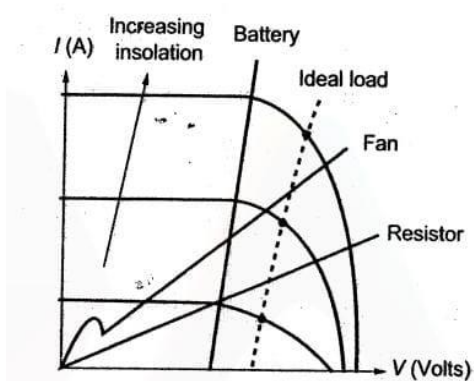

Fig-2.4

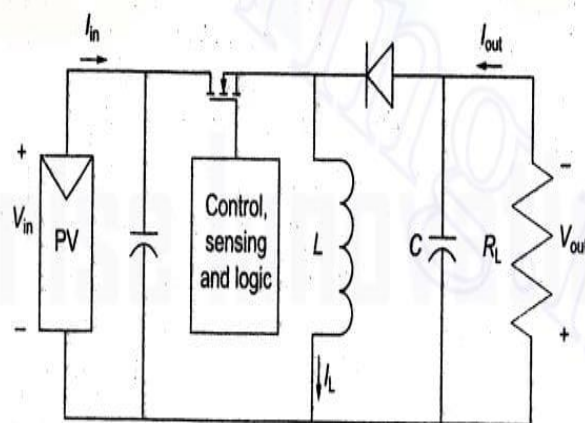

Fig-2.5

- The output voltage of a buck-boost converter is given by  

$$V_{out} = (D/1-D) V_{in}$$
 Where D is duty cycle of MOSFET.

### 2.3 Classification of Energy Sources

- Solar energy is the mother of all forms of energy i.e conventional or non conventional, renewable or non renewable the only exception being nuclear energy.
- Various sources of energy find their origin in the sun are as follows
  1. Wind Energy.
  2. Biomass Energy.
  3. Tidal Energy.
  4. Ocean Wave Energy.
  5. Ocean Thermal Energy.
  6. Fossil fuels and other organic chemicals.
  7. Hydro Energy.

### 2.4 EXTRATERRESTRIAL AND TERRESTRIAL RADIATION

- The solar radiation incident on the outer atmosphere of earth is known as Extraterrestrial radiation.
- Solar constant  $I_{sc}$  is defined as the energy received from the sun per unit time, on a unit area of surface perpendicular to the direction of propagation of the radiation at the top of the atmosphere and at the earth's mean distance from the sun.
- The World Radiation Centre has adopted the value of solar constant as  $1367 \text{ W/m}^2$  ( $1.940 \text{ cal/cm}^2 \text{ min}$ ,  $432 \text{ Btu/ft}^2 \text{ h}$  or  $4.921 \text{ MJ/m}^2 \text{ h}$ ).
- 

$$I_{ext} = I_{sc}(1.0 + 0.033 \cos(360n/365)) \text{ W/m}^2$$

Where  $I_{ex}$  = Extraterrestrial radiation

$I_{sc}$  = Solar constant.

The solar radiation that reaches the earth surface after passing through earth's atmosphere is known as Terrestrial Radiation.

## 2.5 AZIMUTH ANGLE

### 1) Solar Azimuth Angle ( $\gamma_s$ )

- It is the angle on a horizontal plane, between the line due south and the projection of sun ray on the horizontal plane.
- It is taken positive when taken measured from south towards west.

### 2) Surface Azimuth Angle ( $\gamma$ )

- It is the angle on a horizontal plane, between the line due south and the horizontal projection of normal to the incident plane surface (collector) .
- It is taken positive when taken measured from south towards west.

### 3) Zenith Angle ( $\Theta_s$ )

- It is the angle between the angle between the sun's ray and the perpendicular (normal) to the horizontal plane.

### 4) Hour Angle ( $\omega$ )

- Hour angle at any moment is the angle through which the earth must turn to bring the meridian of the observer directly in line with the sun's rays.
- $\omega = (\text{solar time} - 12)(\text{in hours}) * 15 \text{ degree}$

### 5) Solar Constant ( $I_{sc}$ )

- It is defined as the energy received from the sun per unit time, on a unit area of surface perpendicular to the direction of propagation of the radiation at the top of the atmosphere and at the earth's mean distance from the sun.
- The World Radiation Centre has adopted the value of solar constant as  $1367 \text{ W/m}^2$  ( $1.940 \text{ cal/cm}^2 \text{ min}$ ,  $432 \text{ Btu/ft}^2 \text{ h}$  or  $4.921 \text{ MJ/m}^2 \text{ h}$ )

### 6) Solar Irradiance

- It is the power per unit area received from the sun in the form of electromagnetic radiation as measured in the wavelength range of the measuring instrument.
- The solar irradiance is measured in watt per square meter ( $\text{W/m}^2$ ) in SI units.

## 2.6 SOLAR COLLECTORS & ITS TYPES

- A solar thermal collector forms the first unit in a solar thermal system. It absorbs solar energy as heat and transfers it to the heat transfer fluid. The heat transfer fluid delivers this heat to a thermal storage tank/boiler/heat exchanger.

### CLASSIFICATION

- The overall view of classification of solar collectors into categories and subcategories.

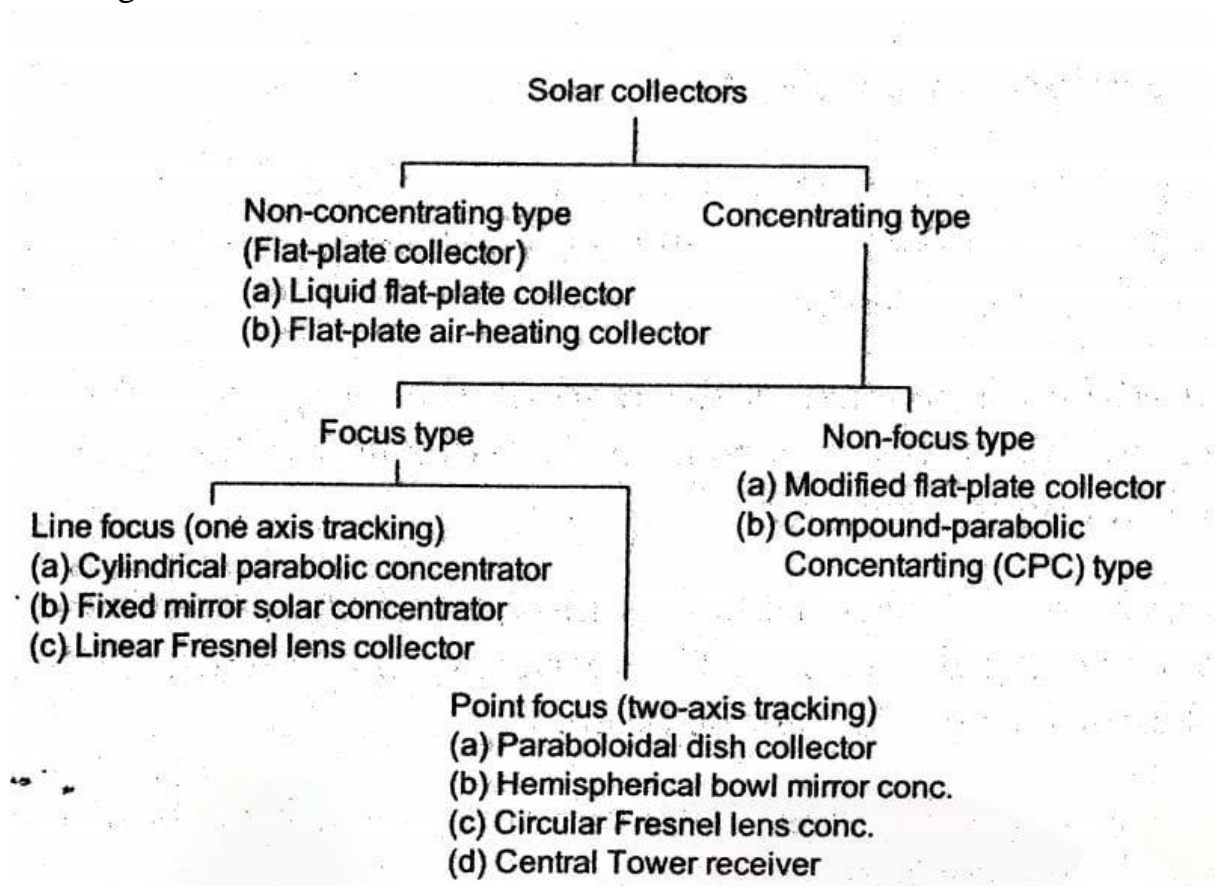

- Non-concentrating type absorbs the radiation as it is received on the surface of the collector.
- These collectors absorb both beam and diffused radiation, as these collectors don't use any optical system, the concentration ratio is 1.
  - a) Liquid flat-plate collector

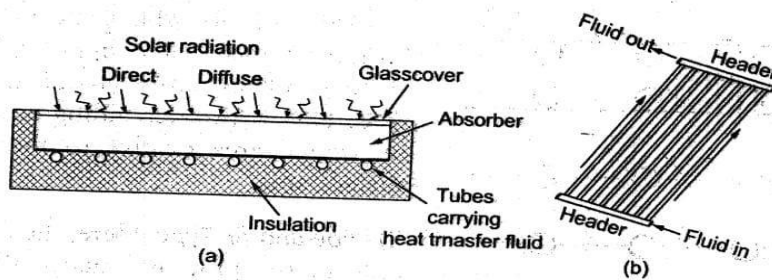

- A flat plate collector is placed at a location in a position such that its length aligns with line of longitude and tilted towards south to have maximum collection.
- The basic elements of these collectors are transparent cover of glass or plastic, blackened absorber plate, tube channels, weather tight insulated container to enclose the components.
- The absorber plate is of three types i.e pipe and fin type, rectangular or cylindrical full sandwich type, roll band or semi- sandwich type.

#### b) Flat plate air heating collector

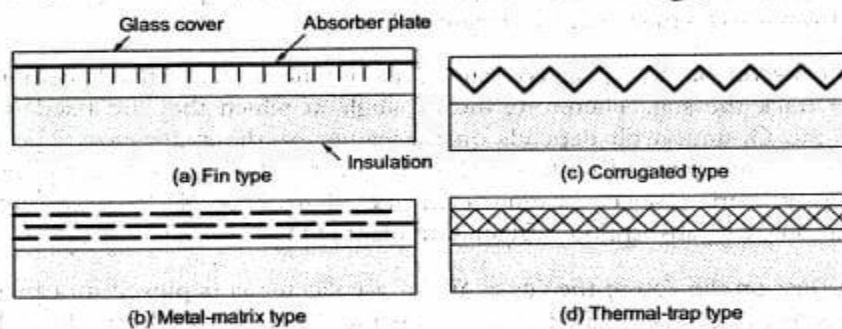

- It is very similar to liquid flat plate collector with change in configuration of absorber and tube.
- The value of heat transfer- coefficient between absorber plate and the air is low.
- The main application is drying agricultural and industrial purpose and space heating.
- Concentrating type-it first increases the concentration of radiation per unit area before absorbing it.It is again of two types
  - I. Focus type.
  - II. Non focus type.

FOCUS TYPE  
(LINE FOCUS)

a) Cylindrical parabolic concentrator.

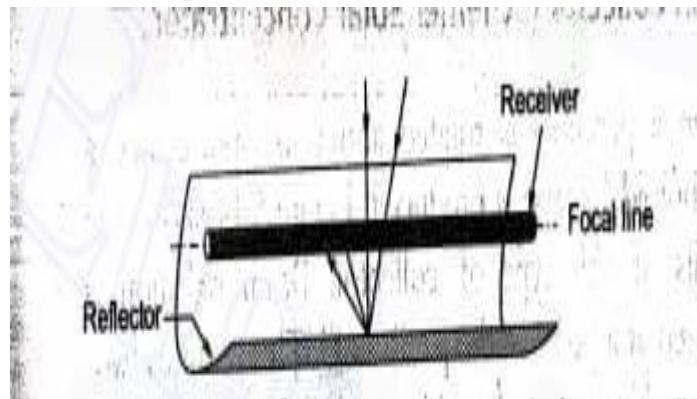

- It consists of a cylindrical parabolic trough reflector and a metal tube receiver at its focal line.
- The receiver tube is blackened outside to increase absorption.
- It may be oriented in any of three directions i.e east-west, north-south, polar.
- The concentration ratio is in the ratio of 5-30.

b) Fixed mirror solar concentrator.

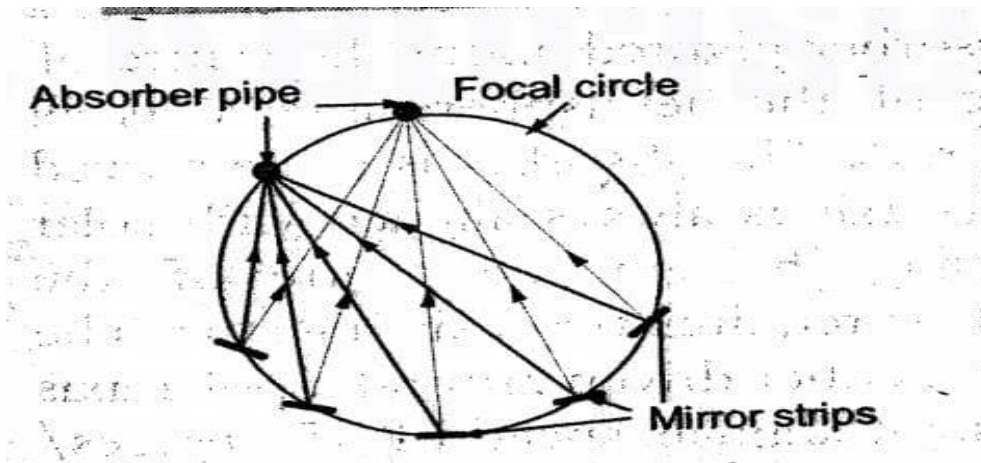

- The concentrator consists of fixed mirror strips arranged on a circular reference cylinder with a tracking receiver tube.
- The concentration ratio is approximately same as the number of mirror strips.

c) Linear Fresnel lens collector.

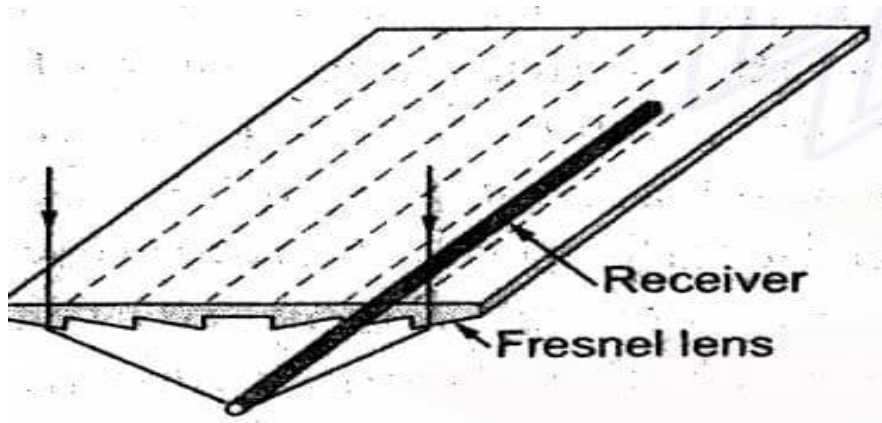

- In this collector a Fresnel lens, which consists of fine, linear grooves on the surface of reflecting material on one side and flat on the other side is used.
- The concentration ratio of 10 to 30 and yields temperature between 150 to 300°C .

(POINT FOCUS)

a) Paraboloidal Dish Collector

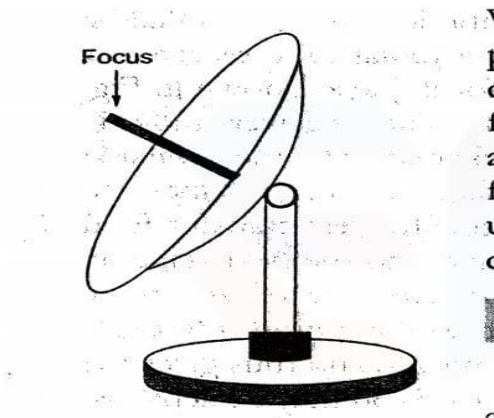

- When a parabola is rotated about its optical axis ,a parabola shape is obtained. This requires two axis tracking.
- It can have a concentration ratio from 10 to few thousands and yield a temperature upto 3000°C.

## b) Hemispherical Bowl Mirror Concentration

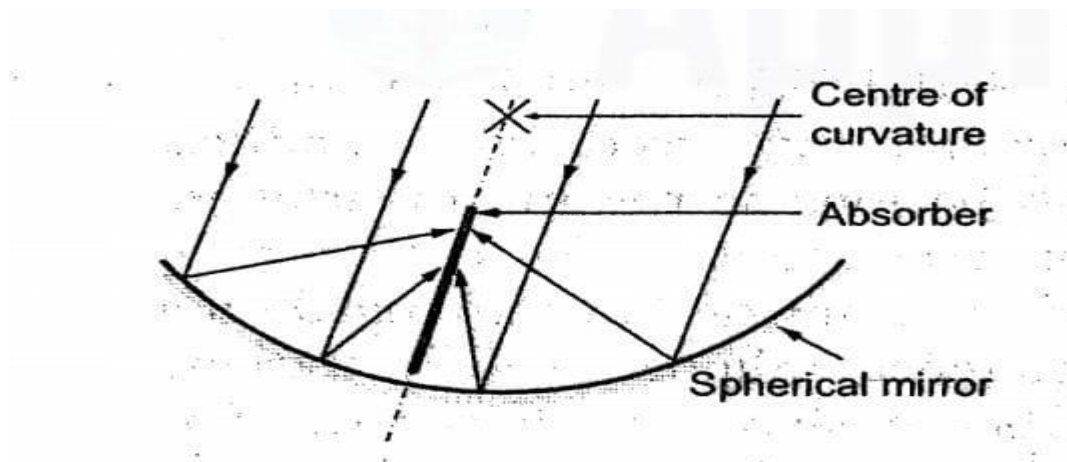

- It consists of a hemispherical fixed mirror, a tracking absorber and a support system.
- This type of concentrator gives lesser concentration than obtained in paraboloidal concentrator

## c) Circular Fresnel lens concentrator

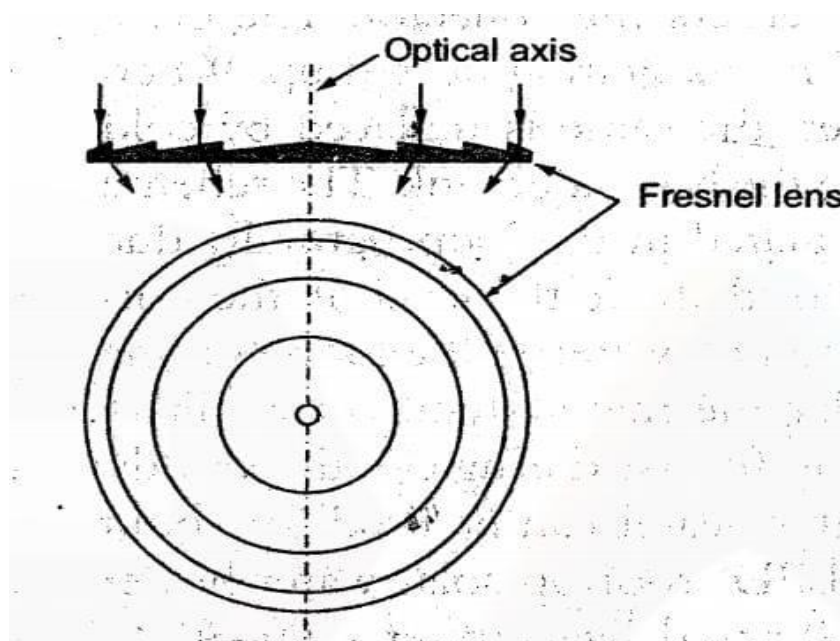

- These lens are generally used where high flux is required.
- Its concentration ratio may be as high as 2000, but is less than that obtained from paraboloidal reflector.

#### d) Central tower receiver

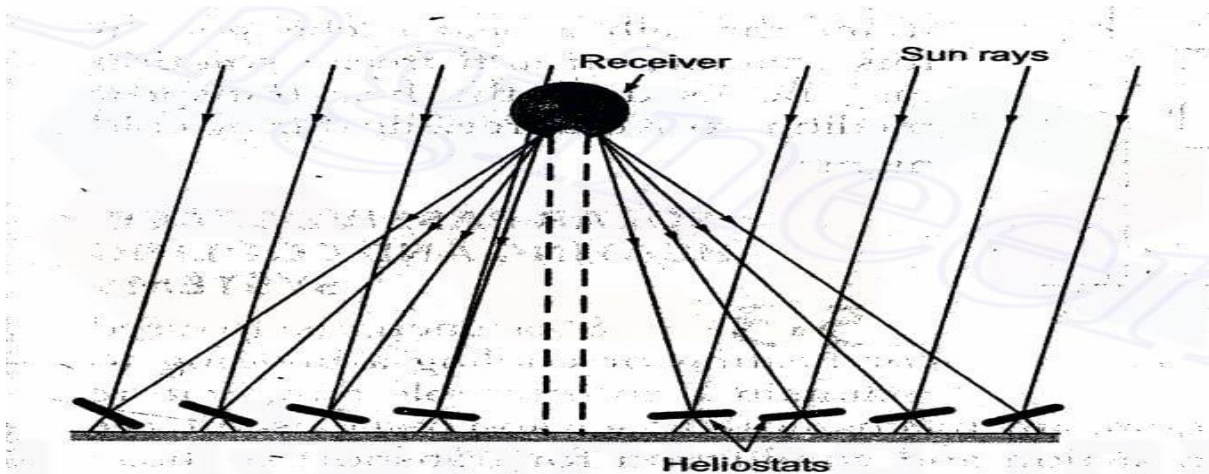

- In this type of collector, the receiver is located at the top of a tower. Beam radiation is reflected on it through a number of independently controlled flat mirrors called heliostats.
- Concentration ratio as high as 3000 can be achieved.

#### NON FOCUS TYPE

##### a) Modified flat plate collector

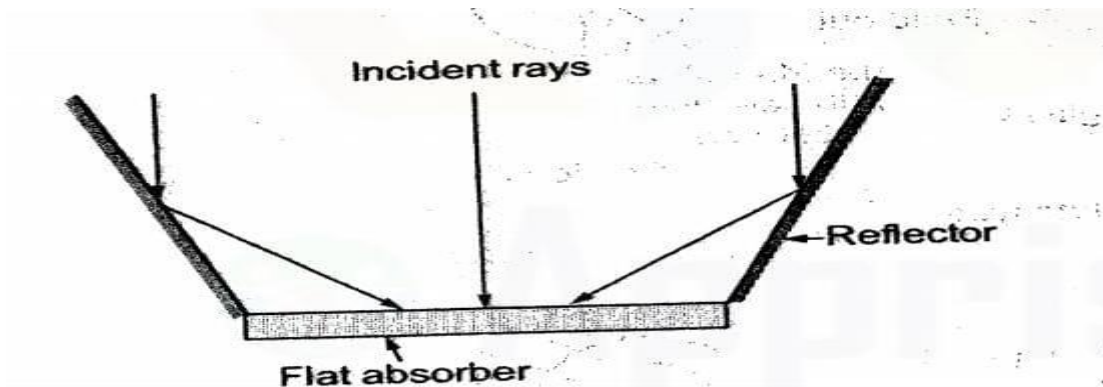

- By providing plane reflector at the edges of a flat plate collector to reflect additional radiation into the receiver, the concentration of solar radiation can be increased.
- The concentration ratio has a maximum value of 4.

## b) Compound Parabolic Concentrator

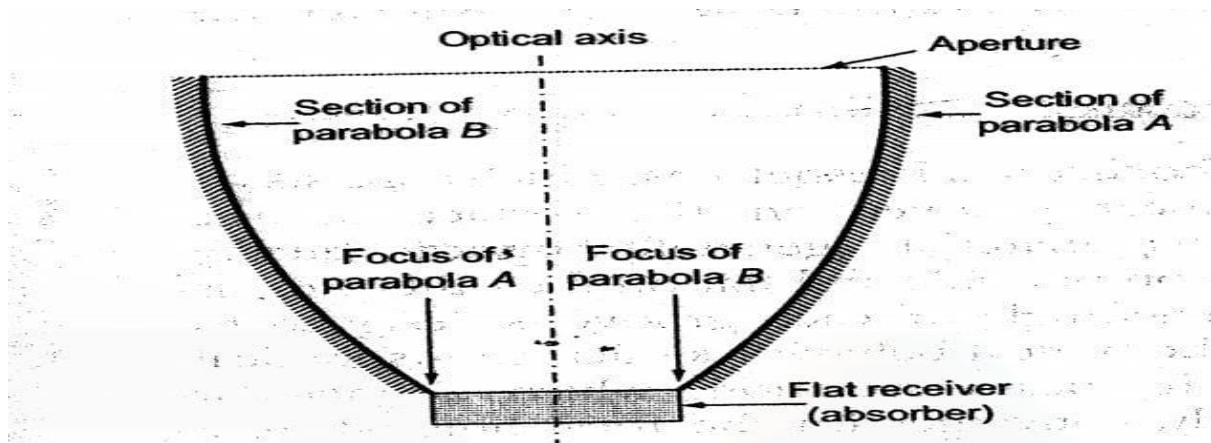

- It consists of two parabolic mirror segments, attached to a flat receiver. It has large acceptance angle and need to be adjusted intermittently.
- The concentration ratio is in the range of 3-7.

## PERFORMANCE INDICES

- The important performance indices of a solar collector are
  1. Collector Efficiency- It is defined as the ratio of the energy actually absorbed and transferred to the heat transport fluid by the collector to the energy incident on the collector.
  2. Concentration Ratio-It is defined as the ratio of the area of aperture of the system to the area of the receiver.
  3. Temperature Range-It is the range of temperature to which the heat transport fluid is heated up by the collector.

## 2.7 APPLICATION OF PHOTO VOLTAIC

### 1. BATTERY CHARGER

- A solar charger is a charger that employs solar energy to supply electricity to device or batteries.
- They are generally portable.
- Solar chargers can charge lead acid or Ni-Cd battery bank upto 48v.

- A series of solar cells are installed in a stationary location( rooftops of homes, base-station locations on ground) and can be connected to a battery bank to store energy for off-peak usage.
- Example-public solar chargers permanently installed in public places ,such as parks, streets.

## 2. DOMESTIC LIGHTING

- The best solar lighting system harnesses the energy of sun for lighting up homes .
- The solar cells transform the solar energy into electricity and this electricity is preserved in batteries.
- The components of this system include solar cells, solar battery, controller, lamps.
- The main advantages that it fits in budget and environment friendly.

## 3. STREET LIGHTING

- Solar street light uses photo voltaic technology to convert sunlight into dc electricity through solar cells.
- The solar street lighting system comprises of PV module ,battery box, lamp with charge controller, lamp post.
- It is ideal for street lighting in remote village.
- The system is provided with automatic on/off time switch for dusk to dawn operation.
- It has lower power consumption, higher intensity, saves electricity cost.

## 4.WATER PUNMPING

- A solar thermal water pump consists of a flat plate collectors, non focusing typecollectors or sun tracking collectors.
- Water is used as a heat transport fluid. Surplus heat is stored in the thermal storage to be used later.

- The high pressure vapour of the working fluid expand in the turbine, condense in the condenser and return in the heat exchanger.

## 5.SOLAR COOKER

- Thermal energy requirements for cooking forms a major share of total energy consumed especially in rural areas.
- Harnessing solar energy for cooking purpose is an attractive and relevant option
- On the basis of design it can be classified into four types i.e box type solar cooker, dish type solar cooker, community solar cooker, advanced solar cooker.

## 6. SOLAR POND ELECTRIC POWER PLANT

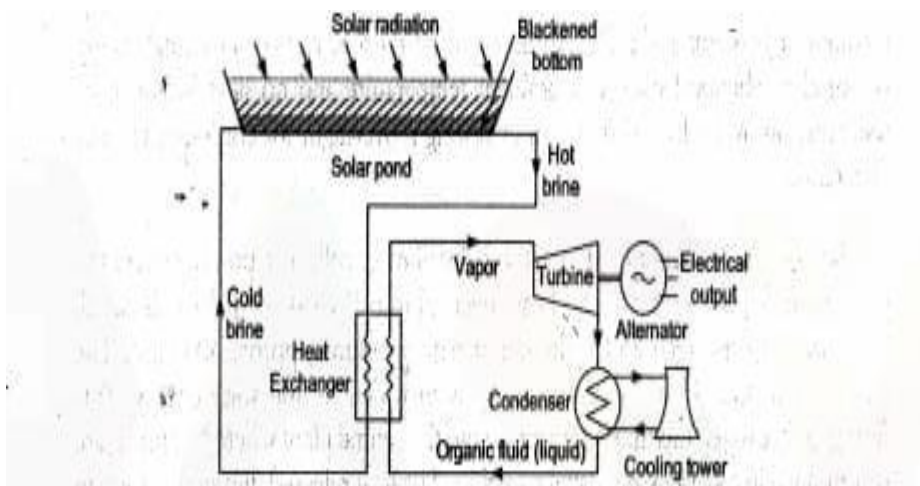

- A solar pond serves the purpose of a large flat- collector as well as long term thermal storage and can provide sufficient heat for the entire year.

- The black bottom serves as an absorber and layer of still water above it is used as an insulator rather than normal glazing and air space.
- In large area pond a vertical salt gradient is maintained. The salt concentration varies from 20-30 percent at the bottom to almost zero at the top.

## QUESTION ANSWER

### Short question and answer

Q 1-Define solar cell.

Ans -Solar Cell

- It is defined as an electrical device that converts light into electrical energy by photovoltaic effect.
- It is a form of photovoltaic cell whose electrical characteristics vary when exposed to light.

Q 2- Define solar PV Module.

Ans-Solar PV Module

- It is an assembly of photovoltaic cells to achieve required voltage and current.
- A solar panel is group of several modules connected in series- parallel combination in a frame that can be mounted on a structure.

Q 3- Define solar PV Array.

Ans- Solar PV Array

- A large number of interconnected solar panels is known as solar PV array.

Q 4- Define Extraterrestrial and Terrestrial Radiation.

Ans- EXTRATERRESTRIAL AND TERRESTRIAL RADIATION

- The solar radiation incident on the outer atmosphere of earth is known as Extraterrestrial radiation
- $I_{ext} = I_{sc}(1.0 + 0.033 \cos(360n/365)) \text{ W/m}^2$

Where  $I_{ex}$ =Extraterrestrial radiation

$I_{sc}$ =Solar constant

- The solar radiation that reaches the earth surface after passing through earth's atmosphere is known as Terrestrial Radiation.

Q 5- Define Azimuth Angle.

Ans-AZIMUTH ANGLE

**Solar Azimuth Angle ( $\gamma_s$ )**

- It is the angle on a horizontal plane, between the line due south and the projection of sun ray on the horizontal plane.
- It is taken positive when taken measured from south towards west.

**Surface Azimuth Angle ( $\gamma$ )**

- It is the angle on a horizontal plane, between the line due south and the horizontal projection of normal to the incident plane surface (collector) .
- It is taken positive when taken measured from south towards west.

Q 6- Define Zenith Angle.

Ans -**Zenith Angle ( $\Theta_s$ )**

- It is the angle between the angle between the sun's ray and the perpendicular (normal) to the horizontal plane.

Q 7- Define Hour Angle.

Ans- **Hour Angle ( $\omega$ )**

- Hour angle at any moment is the angle through which the earth must turn to bring the meridian of the observer directly in line with the sun's rays.
- $\omega = (\text{solar time} - 12) \text{ (in hours)} * 15 \text{ degree}$

Q 8- Define Solar constant

Ans- **Solar Constant ( $I_{sc}$ )**

- It is defined as the energy received from the sun per unit time, on a unit area of surface perpendicular to the direction of propagation of the radiation at the atmosphere and at the earth's mean distance from the sun.

Q 9- Define Solar Irradiance

**Ans- Solar Irradiance**

- It is the power per unit area received from the sun in the form of electromagnetic radiation as measured in the wavelength range of the measuring instrument.
- The solar irradiance is measured in watt per square meter( $W/m^2$ ) in SI units.

Q 10- Define Solar photo voltaic system

**Ans-SOLAR PHOTO VOLTAIC SYSTEM**

- Solar photovoltaic (PV) system convert solar energy directly into electrical energy.
- The basic conversion device used is solar photo voltaic cell or solar cell.

**Long questions**

1. Describe in brief about Maximum Power Point Tracker
2. Explain about solar collector and its types.
3. Write short notes on
  - a) Solar charger
  - b) Solar pond

## CHAPTER -3

### WIND ENERGY

#### **3.1 INTRODUCTION TO WIND ENERGY**

- Wind energy is the kinetic energy associated with movement of large masses of air. These motions result from uneven heating of the atmosphere by the sun, creating temperature, density and pressure differences.
- Wind Energy is harnessed as mechanical energy with the help of wind turbine. The mechanical energy obtained can either be used such as to operate farm appliances and water pumping or converted to electric power and used locally or fed to a grid.
- The generator coupled to a wind turbine is called aero-generator.

#### **3.2 WIND ENERGY CONVERSION**

- Physical energy (kinetic) of wind is first captured by specially designed blade of turbine to rotate it. Mechanical energy of rotating blades is transferred to the rotor of the generator with the help of shaft.
- The generator then converts the mechanical energy into electrical energy. This electrical energy is sent to grids or standalone load through a transformer.
- A general layout for WECS depicting different parts and system are shown in the figure.

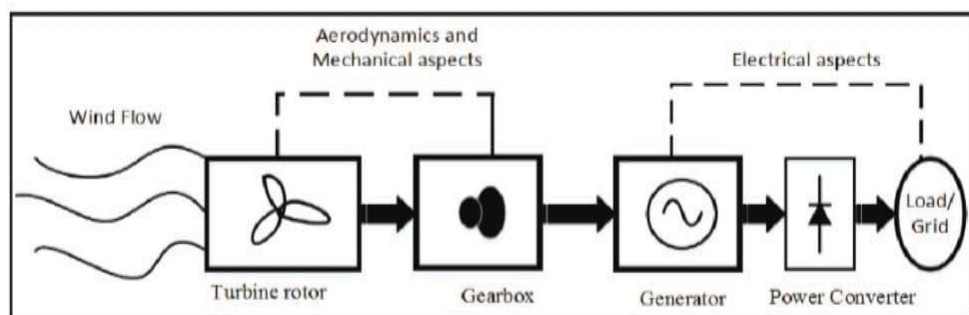

- Turbine Rotor-The production of power due to wind turbine depends upon the interaction between wind and rotor. The rotor consists of large turbine blades and hub.
- Gear Box-The rotational speed of wind turbine is typically around 100 RPM, which is not sufficient to produce electricity as most generators

need the speed of 1000-3600 RPM. Gearbox is used to increase the speed of the generator rotor to 1000-3600 RPM to make the generator functional.

- Generator- The mechanical energy of wind turbine rotor is converted into electrical energy through generator. The ac generator (asynchronous and synchronous) are generally found in wind turbine motor.
- Power Converter-It eliminates the need of gearbox which is the main reason of power losses and failure in wind turbine system. To meet the huge growing demand of the wind energy conversion system power converter are developed to achieve power conversion at higher voltage level.

### **3.3 Types of Wind Turbines**

- Wind turbines are broadly classified into two categories
  - a) Horizontal Axis Wind Turbine. (HAWT)
  - b) Vertical Axis Wind Turbine. (VAWT)

#### **Horizontal Axis Wind Turbine. (HAWT)**

- When the axis of rotation is parallel to air stream it is called Horizontal Axis Wind Turbine. (HAWT).
- HAWTs have emerged as the most successful type of turbines. These are used for commercial energy generation in many parts of the world.
- The constructional details of a three blade rotor, horizontal axis wind turbine is shown below. The main parts are as follows.

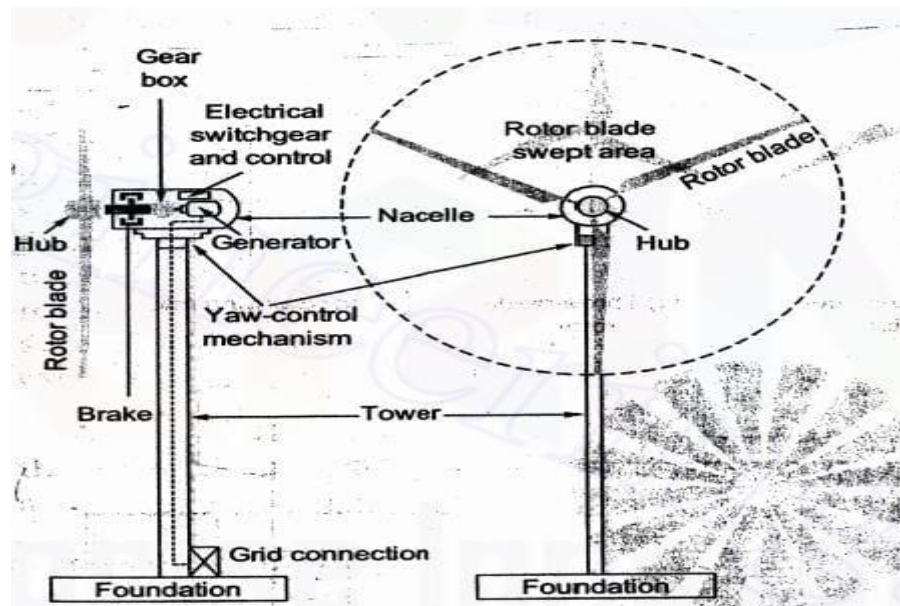

a) Turbine Blade-It is made of high-density wood or glass fibre and epoxy composites. The blades are slightly twisted from the outer tip to the rotor to reduce the tendency to stall. Diameter of a typical, MW range modern rotor may be of the order of 100m.

➤ Modern wind turbines have two or three blades. Two/three rotor HAWT are known as propeller –type wind turbine.

b) Hub-The central solid portion of the rotor wheel is known as hub.

All blades are attached to the hub. The mechanism for pitch angle control is also provided inside hub.

c) Nacelle-The rotor is attached to the nacelle and mounted at the top of a tower. It contains rotor brakes ,gearbox, generator and electrical switchgears and control.

d) Yaw -control Mechanism- The mechanism to adjust the nacelle around the vertical axis to keep it facing the wind is provided at the base of the nacelle.

e) Tower- The tower supports the nacelle and rotor. For medium and large sized turbines, the tower is slightly taller than the rotor diameter. Both steel and concrete towers are being used. The construction can be either tubular or lattice.

### **Vertical Axis Wind Turbine. (VAWT)**

➤ When the axis of rotation is perpendicular to the stream it is said to be vertical axis wind turbine.

- The main attraction of a VAWT are as follows
  - It can accept wind from any direction eliminating the need of yaw control.
  - The gearbox, generator, etc are located at the ground eliminating the need of heavy nacelle at the top of the tower.
  - Inspection and maintenance is easier.
  - Overall cost is reduced.
- The main components of a (Darrieus type rotor) VAWT are as follows

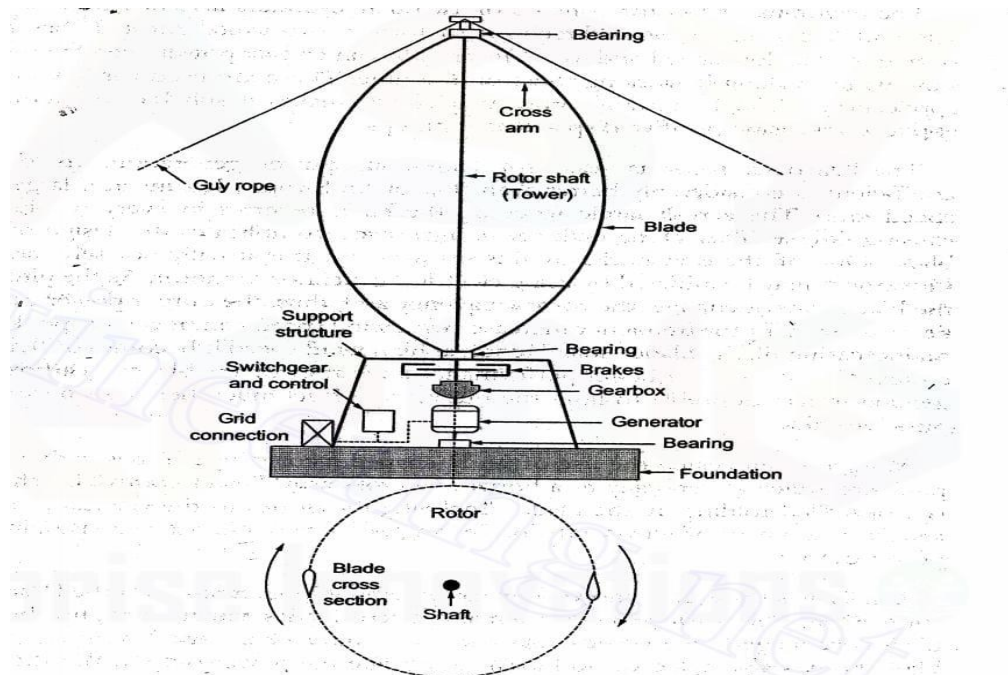

- Tower or Rotor Shaft – The tower is a hollow vertical rotor shaft, which rotates freely about the vertical axis between the top and bottom bearing . The upper part of the tower is supported by guy ropes. The height of the tower of a large turbine is around 100m.
- Blades- It has two or three thin, curved blades like an eggbeater in a profile, with blades curved in a form that minimises the bending stress caused by the centrifugal forces –so called “Troposkien” profile. The diameter of the rotor is slightly less than the tower height.
- Support Structure- It is provided at the ground to support the weight of the rotor, gearbox, brakes, electrical switchgear and controls and housed within this structure.

### 3.4 Aerodynamics of Wind Rotors

- Aerodynamics deals with the movement of solid bodies through the air. It provides a method to explain the relative motion between airfoil and air.
- Airfoil is the cross-section of the wind turbine blade when the wind passes over the surface of the rotor blade, then it automatically passes over the longer and upper side of the blades which creates a low pressure area above the airfoil.
- The pressure difference between the top and the bottom surface results in a force called aerodynamic lift that causes the airfoil to rise.
- When air flows over solid bodies, several physical phenomena are noticed such as drag force acting on the objects like trees, electric towers and lift force developed by airplane wings and experienced by dust particles in a wind storm and the blade motion developed by a turbine.
- Drag Force- It is the force exerted on the solid body by the fluid in the direction of flow.
- Lift Force- It is the force exerted on the solid body by the fluid and perpendicular to the direction of flow.

### 3.5 Wind turbine control systems

- Wind turbine requires certain control mechanism to protect generator and turbine from strong winds and to capture the power as much as possible at low and medium winds.
- The wind turbine has 4 different control mechanisms such as
  - a) Pitch angle control (Y-control).
  - b) Stall ( $\alpha$ ) control.
  - c) Yaw control.
  - d) Power electronic control.
- a) Pitch angle control (Y-control)

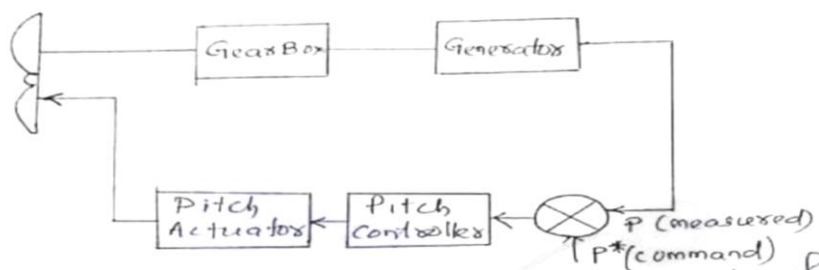

- This system changes the pitch angle of the blades according to the variation of wind speed. It is possible to achieve a high efficiency by continuously aligning the blades in the direction of relative wind.
- The input variable to the pitch controller is an error signal which is the difference between the output electrical power and reference power.
- The pitch controller operates the blades actuator to change the pitch angle. The generator must be able to absorb the mechanical power output of the turbine and deliver output power needs to be simultaneously adjusted.

#### b) Stall ( $\alpha$ ) control

- It means control of the angle of attack w.r.t increase in wind speed. These are of two types such as passive stall control and active stall control.
- Passive control is used to limit the power output at high winds which is applied to constant pitch turbines driving induction generators.
- Active stall control involves rotation of blades by a few degree in the direction opposite to the pitch control machine at high wind speeds.
- This control is also called as deep control.

#### c) Yaw Control

- This control orients the turbine continuously along the direction of wind flow. This is achieved by mounting a small turbine perpendicular to the main turbine in case of large machines and by providing a tail-vain in case of small machines.
- Yaw control can also be achieved without any additional mechanism by mounting the turbine downward.

#### d) Power Electronic Control

- The electrical power delivered by the generator to the load can be dynamically controlled in a system incorporating a power electronic interface between the generator and the grid.

### Wind Energy to Electrical Energy

- Wind turbines use blades to collect the wind's kinetic energy. Wind flows over the blades creating lift which causes the blades to turn. The blades are connected to a drive shaft that turns an electric generator which generates electricity.
- The amount of wind electricity generation has grown significantly in past 30 years. Advances in wind energy technology has decreased the cost of producing electricity from wind.

### 3.6 Induction and Synchronous Generators

**Induction Generator-** These are used because of constant frequency output, low capital cost, low maintenance and better transient performance.

- The induction generators require an ac excitation current which is mainly reactive. The current can be drawn from grid or utility bus where the voltage and frequency are determined by the grid or from the generator itself by providing shunt capacitors known as standalone system.
- The variation of shaft speed is absorbed in the slip.

**Synchronous Generator-** Synchronous generators which produce high quality output are universally used for power generation in conventional plants.

- But these are not suitable for wind power plants because of variation in frequency of generated output w.r.t rotor speed. Also precise rotor speed control is required for synchronisation.

### **3.7 Grid Connected and Self Excited Induction Generator Operation**

- Induction generators are not self-starting , they require an electric supply to produce rotating magnetic flux. The current can be drawn from grid or utility bus where the voltage and frequency are determined by the grid or from the generator itself , once it starts producing power the rotating magnetic flux from the stator induces current in the rotor which also produces a magnetic field.
- If the rotor turns faster than the rate of rotating flux, then the machine acts like a generator which produces power at synchronous frequency.

#### **Grid Connected Induction Generator Operation**

- The generated power is feed to the supply system when the rotor is driven above synchronous speed.
- Machines with cage type rotor feed only through the stator and generally operate at low negative slip.
- Wound rotor machines can feed power through the stator as well as the rotor to the bus over a wide speed range.

#### **Self Excited Induction Generator Operation**

- A capacitor when connected across the induction machine helps in building up the terminal voltage. But the build up of the voltage also depends on factors such as speed, capacitor value and load.
- The squirrel cage machine is generally used as self-excited induction generator.
- Based on the methods of excitation, induction generators are classified into two categories such as
  - I. Constant-voltage-constant-frequency generators and
  - II. Variable-voltage-variable-frequency generators.

### **3.8 Constant Voltage and Constant Frequency Generation With Power-Electronic Control**

- An induction machine in the generating mode operates fundamentally in the same manner as in the rotating mode expect for the reversal of power flow. Hence, the equivalent circuit and the associated performance equations using motoring convections are valid for all values of slip.

- If the rotor is driven by a prime mover above the synchronous speed in the direction of the air-gap field with the stator winding remaining connected to the utility grid and the prime-mover is converted into electrical power.

### 3.9 Single And Double Output Systems

#### Single output system

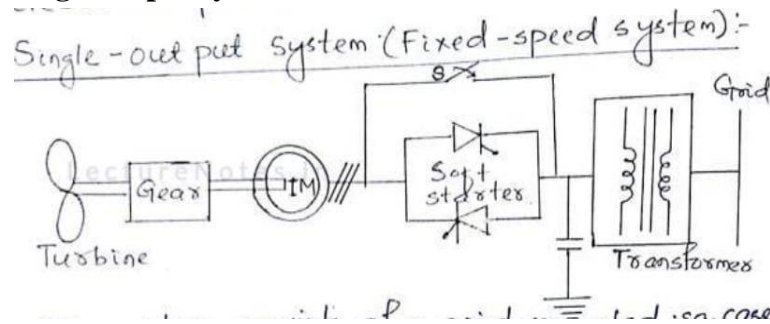

- The system consists of a grid connected squirrel cage induction generator coupled to turbine through gear box.
- The gear box steps up the rotor speed to a value matching a 50Hz or 60Hz utility n/w. The generator always draws reactive power from the network.
- Capacitors are used to compensate lagging VAR. As the generator is coupled to the grid the speed varies over a very small range above synchronous speed which is around 1%.
- As the speed variation is small, so the system is commonly known as a fixed speed system.

#### Double output system

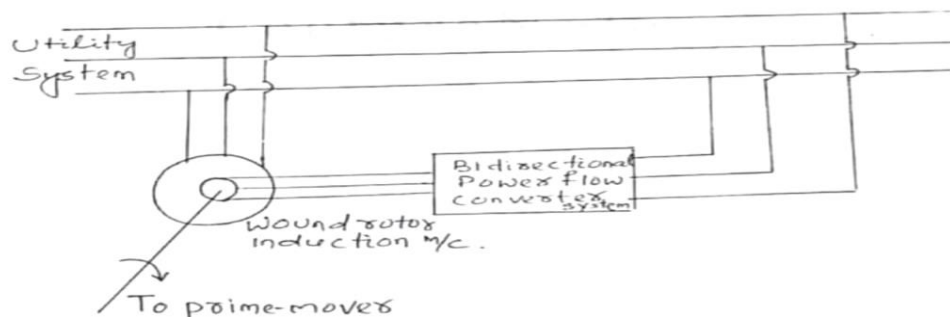

- Power can be feed into the supply system over a wide range of speed by appropriately controlling the rotor power from a variable frequency source with a slip-ring induction machine.
- The provision for bidirectional flow of power through the rotor circuit can be achieved by the use of a slip-ring induction motor with an ac/dc/ac converter connected between the slip-ring terminals and the utility grid.
- The system is known as a double-output induction generator because power can be tapped both from the stator and from rotor.

### 3.10 Characteristics of Wind Power Plant

- No CO<sub>2</sub> emission.
- Wind is a safe energy source existing everywhere, and there is no need to worry about its depletion like fossil fuels.
- Simple Equipments and easy operation.
- Few affection to nature environment.

### Question And Answer

#### Short Question And Answer

1. Draw the basic diagram of Wind Energy Conversion System.

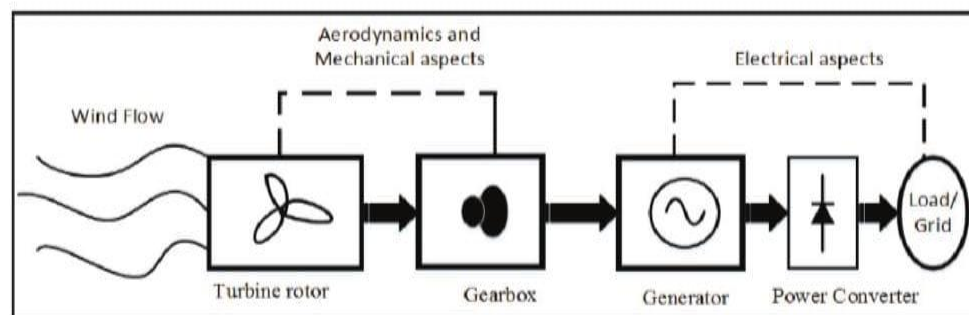

Ans-

2. Write the types of Wind Turbines.

Ans- Wind turbines are broadly classified into two categories

- a) Horizontal Axis Wind Turbine. (HAWT)
- b) Vertical Axis Wind Turbine. (VAWT)

3. Write the types of Wind turbine control systems

Ans- Wind turbine requires certain control mechanism to protect generator and turbine from strong winds and to capture the power as much as possible at low and medium winds.

- The wind turbine has 4 different control mechanism such as
  - a) Pitch angle control (Y-control).
  - b) Stall ( $\alpha$ ) control.
  - c) Yaw control
  - d) Power electronic control.

**4. Based on the type of excitation induction generator are classified into how many types?**

**Ans-** induction generators are classified into two categories such as

- I. Constant-voltage-constant frequency generator.
- II. Variable-voltage-variable frequency generator.

**Long Question with Hints**

- 1. With a neat diagram explain wind energy conversion system.**
- 2. With a neat diagram explain Horizontal Axis Wind Turbine. (HAWT).**
- 3. With a neat diagram explain Vertical Axis Wind Turbine. (VAWT).**
- 4. Explain in brief about the different Wind turbine control systems.**
- 5. Write short notes on**
  - a)Single output system.**
  - b)Double output system.**

## Chapter-4

### BIOMASS POWER

#### 4.1 Energy from Biomass

- Biomass is a general term which refers to the mass of biological material produced from the living processes. This includes the material derived from the plants as well as from animals.
- The energy obtained from biomass is known as biomass energy. Animals feed on plants and plants grow through photosynthesis process using solar energy, thus photosynthesis process is primarily responsible for generation of biomass energy.
- The average efficiency of photosynthesis conversion of solar energy is estimated to be 0.5% to 1%.
- Biomass is a derivative of solar energy as plants grow by the process of photosynthesis by absorbing  $\text{CO}_2$  from the atmosphere to form carbohydrates such as sugar, starch, and cellulose etc or hexose such as glucose etc.
- $6\text{CO}_2 + 6\text{H}_2\text{O} + \text{Light} \rightarrow \text{C}_6\text{H}_{12}\text{O}_6 + 6\text{CO}_2$
- Biomass does not add  $\text{CO}_2$  to the atmosphere as it absorbs the same amount of carbon in growing the plants as it releases when consumed as fuel.

#### 4.2 Biomass as Renewable Energy Source

- Biomass is a key renewable energy source that includes plant and animal material. The energy contained in biomass originally came from plants through photosynthesis.
- In the process of photosynthesis carbon dioxide in air is transformed into other carbon-containing molecules like sugar, starch and cellulose in plants.
- The chemical energy that is stored in plants and animals or in their waste is called biomass energy or bio-energy.
- Biomass comes from a variety of sources which include
  - Wood from woodland and natural forest.
  - Forestry Plantation.
  - Agricultural residue such as straw, stover, cane trash and green agricultural wastes.
  - Animal waste like cow manure, poultry litter.
  - Sewage.
  - Municipal Solid Waste.
  - Food Processing Waste.

### 4.3 Types Of Biomass Fuels

- Biomass is a organic material that reacts with oxygen in combustion and metabolic processes to release heat.
- Sometimes it is used in its original form but more often it is transformed into modern energy forms such as liquid and gaseous fuels, electricity and processes heat to provide energy service to rural and urban areas. Some of its form available to user are as follows.
  - I. Fuel Wood-It is the most obvious and oldest source of biomass energy and direct combustion is the simplest way to obtain heat energy from it. It can also be converted to more useful forms such as charcoal and producer gas. Its energy density is 16-20 MJ/Kg.
  - II. Charcoal- It is a clean, dry, solid fuel , black in colour. Its energy density is about 30MJ/Kg. It is obtained by carbonisation process of woody biomass to achieve higher energy density per unit mass.
  - III. Fuel Pellets and Briquettes-Crop residue such as straw, rice husk and waste wood are pressed to form lumps, known as fuel pellets or briquettes and used as solid fuel. The purpose is to reduce the moisture content and increase the energy density of biomass to make it more feasible for long distance transportation.
  - IV. Bio-diesel- Some vegetable oils, edible as well as non edible, can be used in pure form or blended with petroleum diesel as a fuel in a compression – ignition engine. Bio-diesel is simple to use, biodegradable, non- toxic and free of sulphur and aromatics.

### 4.4 Combustion And Fermentation.

**Combustion-** Incineration means direct combustion of biomass for immediate useful heat. The heat or steam produced are either used to generate electricity or provide the heat for industrial process, space heating, cooking.

Furnaces and boiler have been developed for large- scale burning of various types of biomass such as wood, waste wood, black liquid from pulp industry, food industry and MSW.

**Fermentation-** It is the process of decomposition in the absence of air of simple hexose sugars in aqueous solution by action of an enzyme present in yeast in acidic condition thus the products are ethanol and carbon dioxide.

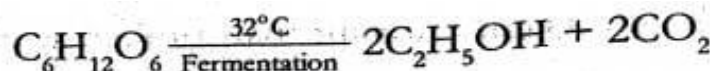

## 4.5 Anaerobic Digestion

- This process converts decaying wet biomass and animal wastes into biogas through the decomposition process by the action of anaerobic bacteria. Carbon present in biomass may be divided between fully oxidized  $\text{CO}_2$  and fully reduced  $\text{CH}_4$ .

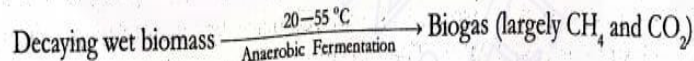

- The biomass material in the form of water slurry is digested by the bacteria anaerobically for several days in an air tight container. The reactions are slightly exothermic and small amount of heat is also generated to maintain a favourable temperature.
- The most useful biomass material appear to be animal manure, algae, kelp, hyacinth, plant residues and other organic material with high moisture content.

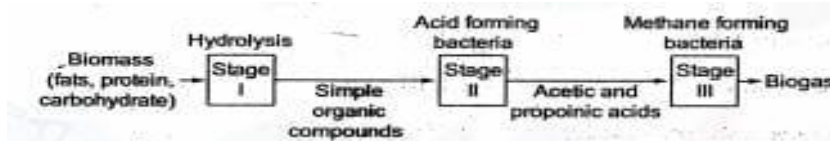

- Anaerobic digestion has three stages.
- Stage I- First of all the original organic matter containing complex compounds is broken through the influence of water known as hydrolysis to simple water soluble compounds.
- Stage II- The anaerobic micro-organisms and facultative together known as acid former produce acetic and propionic acid, this process takes about one day at  $25^\circ\text{C}$  and mostly carbon dioxide is released at this stage.
- Stage III- The anaerobic bacteria also known as methane formers slowly digest the products available from second stage to produce methane, carbon dioxide, a small amount of hydrogen and a trace amount of other gas. The process takes about two weeks time to complete at  $25^\circ\text{C}$ . Third stage is carried out strictly by anaerobic bacteria.
- Advantages of Anaerobic Digestion are as follows
  - Discarded waste material is used to produce energy.
  - In anaerobic digestion we obtain both fuel and fertilizer.
  - Anaerobically obtained manure is better in terms of both quantity and quality as compared to ordinary manure.
  - Since the system is enclosed, the digested slurry is odourless.

## 4.6 Types Of Biogas Digester

- A biogas digester is a closed container in which the segregation and feeding of the organic substrate takes place. In this digester the biodegradation of substrate takes place under anaerobic conditions and in the presence of methanogenic bacteria, producing a methane rich bio-gas.
- Biogas digester are mainly classified as
  - I) Batch type
  - II) Continuous type.

- Continuous type is again divided into two types
  - a) Floating- drum type.
  - b) Fixed-dome type.
- BATCH TYPE-A batch-type plant is charged at 50-60 day intervals. Once charged it starts supplying gas after 8-10 days and continues to do so for about 40-50 days till the process of digestion is completed. The battery of the digester are charged and emptied one by one in a synchronous manner to maintain a regular supply of gas through a common gas holder. The installation and operation of such plants are capital and labour intensive and are not economical unless operated on large scale. These plants are installed in European countries and it is not suitable for Indian rural areas.
- CONTINUOUS TYPE- The plant is fed daily with a certain quantity of biomass. The gas produced is stored in the plant or in a separate gas holder and remains available for use as required. The biomass while slowly passing through the digester is completely digested and the digested slurry is rejected through an outlet. The period during which the biomass remains in the digester is known as the retention period, which depends mainly on the type of biomass and operating temperature. The plant operates continuously and is stopped only for maintenance or for removal of sludge. A thin dry layer often formed at the top of the slurry known as scum. The scum tends to prevent the escape of gas from slurry. This type of plants are very popular in India and china.

#### Floating Drum Type Biogas Plant

- It has an inverted mild steel drum to work as gasholder.
- The digester is an underground masonry construction with partition wall ,which provides optimum conditions for growth of acid formers and methane formers as  $p^H$  value required for these bacteria are different. Therefore the plant operates very well with good gas yield

#### Fixed-Dome Type Biogas Plant

- These plants are more economical as only masonry work is required.
- Gas pressure in the dome varies depending on the production/consumption rate.
- The slurry enters from an inlet and the digested slurry is collected in a displacement tank, stirring is required if the raw material is crop residue.
- There is no bifurcation in the digester chamber and therefore the gas production is less as compared to floating-drum type biogas plant.
- The gas produced is stored in the dome and displaces the liquids in inlet and outlet, often leading to gas pressure as high as 100cm of water. The gas occupies about 10% of the volume of the digester.
- As the complete plant is constructed underground the temperature tends to remain constant and is often considerably higher than the ambient temperature in winter.

## 4.7 WOOD GASIFIER

- It is capable of burning wood fuel or wood derived biomass fuel.
- It consists of a solid metal usually cast iron or steel closed fire chamber, a grate and an adjustable air control.
- The appliance will be connected to a suitable chimney or flue which will fill with hot combustion gases once the fuel is ignited.
- It is critical that the chimney or flue gases be hotter than the outside temperature as this will result in combustion gases being drawn out of the fire chamber and up the chimney.

### Advantages

- Availability- The fuel is readily available in most locations, as wood is harvested locally or can be provided by vendors.
- Renewability- Wood is a renewable fuel. The growth of new forests for timber and fuel is a huge and established industry.
- Simplicity- They are easy to use as they tend to have few moving parts.
- Reliability- These are highly reliable as they do not require electricity to operate.

### Disadvantage

- Maintenance- It need to be maintained regularly as they add ashes which need to be removed periodically.
- Fuel cost- Firewood are expensive in some parts of the country because there are no nearby source particularly in urban areas.

## 4.8 PYROLYSIS

- It is most commonly used in the treatment of organic materials. It is the first step in the processes of gasification.
- It is one of the processes involved in charring wood.
- The process is used heavily in the chemical industry, for example to produce ethylene, many forms of carbon and other chemicals from petroleum, coal, and even wood, to produce coke from coal.
- Pyrolysis generally consists in heating the material above its decomposition temperature, breaking chemical bonds in its molecules.
- When organic matter is heated at increasing temperature in open containers, the following processes generally occur.
  - Below about 100°C, volatiles including some water, heat sensitive substances such as vitamin C and proteins, may partially change or decompose at this stage.
  - At above 100°C or slightly higher, any remaining water that is merely absorbed in the material is driven off. This process consumes a lot of energy, so the temperature may stop rising until all water has evaporated.
  - Some solid substances like fats, waxes, and sugar, may melt and separate.

- Below 100 and 500°C, many common organic molecules breakdown. At this point the matter is said to have been charred or carbonised.
- At 200-300°C, if oxygen has not been excluded, the carbonaceous residue may start to burn in a highly exothermic reaction.
- Once combustion of the carbonaceous residue is complete, a powdery or solid mineral residue is left behind.

#### **4.9 Application of Biogas, Bio-diesel**

- The following are the application of Biogas
  - Electricity generation- Biogas made from plant material offers a renewable way to generate electricity.  
Biogas possesses chemical energy, and electricity is produced by converting this chemical energy to mechanical energy and finally into electricity. This electricity can be used both domestically and commercially since it can be made in small and large scale.
  - Waste management in agriculture- After electricity generation another most important application of biogas is for agriculture waste management. Crop waste and manure can be digested either alone or in co-digestion with other material employing either wet or dry processes.
  - As a Renewable fuel for transport vehicles- If concentrated and compressed an ideal application of biogas exists in vehicle transportation. Compressed biogas is widely used in Sweden, Switzerland and Germany.
  - Fuel Cells- Theoretically, biogas can be converted directly into electricity using a fuel cell.
- The following are the applications of Bio-diesel
  - It can be used as heating oil in domestic and commercial boilers.
  - It is also used to clean oil-spills.
  - Bio-diesels are used in generators allowing companies to avoid damaging blackouts.

## **Question and Answer**

### **Short Question and Answer**

#### **1. What is Biomass ?**

**Ans-** Biomass is a general term which refers to the mass of biological material produced from the living processes. This includes the material derived from the plants as well as from animals.

#### **2. What are the source of biomass**

**Ans-**Biomass comes from a variety of source which include

- Wood from woodland and natural forest.
- Forestry Plantation.
- Agricultural residue such as straw, strove, cane trash and green agricultural wastes.
- Animal waste like cow manure, poultry litter.
- Sewage.
- Municipal Solid Waste.
- Food Processing Waste.

#### **3. What are the advantages of anaerobic digestion.**

**Ans-** Advantages of Anaerobic Digestion are as follows

- Discarded waste material is used to produce energy.
- In anaerobic digestion we obtain both fuel and fertilizer.
- Anaerobically obtained manure is better in terms of both quantity and quality as compared to ordinary manure.
- Since the system is enclosed, the digested slurry is odourless.

#### **4. What are the advantage of wood gasifier.**

**Ans-** The following are the advantages of wood gasifier

- Availability- The fuel is readily available in most locations, as wood is harvested locally or can be provided by vendors.
  - Renewability-Wood is a renewable fuel. The growth of new forests for timber and fuel is a huge and established industry.
  - Simplicity- They are easy to use as they tend to have few moving parts.
  - Reliability- These are highly reliable as they do not require electricity to operate.
- Disadvantage
- Maintenance- It need to be maintained regularly as they add ashes which need to be removed periodically.

- Fuel cost-Firewood are expensive in some parts of the country because there are no nearby source particularly in urban areas.

### 5. What is anaerobic Digestion?

**Ans-** This process converts decaying wet biomass and animal wastes into biogas through the decomposition process by the action of anaerobic bacteria .Carbon present in biomass may be divided between fully oxidized  $\text{CO}_2$  and fully reduced  $\text{CH}_4$  .

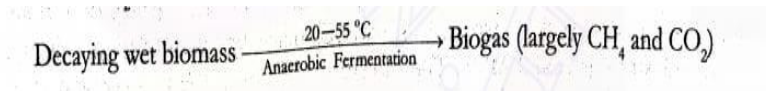

### Long Question

1. Explain the process of anaerobic digestion.
2. Explain in brief the types of biogas digester.
3. Explain in brief the process of pyrolysis.